

Physics 151 Class Exercise: Torque 2-KEY

1. A school yard teeter-totter with a total length of 5.2 m and a mass of 36 kg is pivoted at its center. A 18-kg child sits on one end of the teeter-totter.
 - (a) Where should a parent push vertically downward with a force of 210 N in order to hold the teeter-totter level?
 - (b) Where should the parent push with a force of 310 N?
 - (c) How would your answers to parts (a) and (b) change if the mass of the teeter-totter were doubled? Explain.

It is certainly easiest to solve for x by summing torques about the pivot point. That way we don't have to solve for N – we could get N from a summation of forces in the y direction, but it is unneeded extra work.

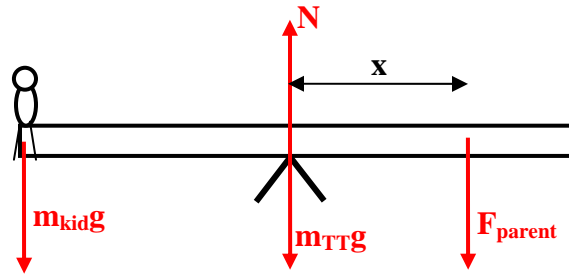

$$\Sigma \tau_{pivot} = -m_{kid}g \frac{l}{2} + F_{parent}x = 0$$

$$x = \frac{m_{kid}gl}{2F_{parent}} = \frac{(18kg)\left(9.81 \frac{m}{s^2}\right)(5.2m)}{2(210N)} = 2.2m$$

$$x = \frac{m_{kid}gl}{2F_{parent}} = \frac{(18kg)\left(9.81 \frac{m}{s^2}\right)(5.2m)}{2(310N)} = 1.5m$$

- (c) The answers would not change since only the teeter-totter's length enters into the calculations (the child sits half a length from the pivot point).

2. When you arrive at Duke's Dude Ranch, you are greeted by the large wooden sign shown in the figure below. The left end of the sign is held in place by a bolt, the right end is tied to a rope that makes an angle of 20.0° with the horizontal. If the sign is uniform, 3.20 m long, and has a mass of 16.0 kg, what is (a) the tension in the rope, and (b) the horizontal and vertical components of the force, \mathbf{F} , exerted by the bolt?

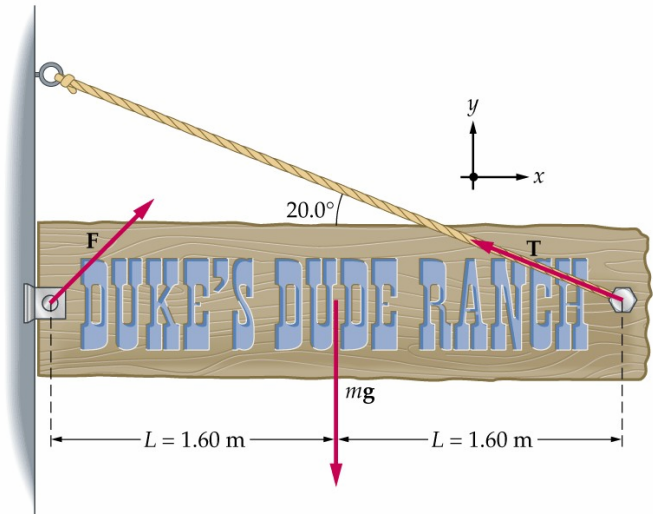

Note that from the sign's point of view the situation is symmetric: it has a movable support at each end and doesn't "know" whether the support is a wall or a wire. So, the force at the wall bolt is the same as it would be if the wall were instead a wire running up and to the right at 20.0° above horizontal. By symmetry, $f = T$ and $\sum F_y = 2T \sin \theta - mg = 0$.

$$(a) \quad T = \frac{mg}{2 \sin \theta} = \frac{(16.0 \text{ kg}) \left(9.81 \frac{\text{m}}{\text{s}^2} \right)}{2 \sin 20.0^\circ} = \boxed{229 \text{ N}}$$

$$F_x = F \cos \theta = T \cos \theta = (229.5 \text{ N}) \cos 20.0^\circ = \boxed{216 \text{ N}}$$

$$(b) \quad F_y = F \sin \theta = T \sin \theta = \frac{mg}{2} = \frac{(16.0 \text{ kg}) \left(9.81 \frac{\text{m}}{\text{s}^2} \right)}{2} = \boxed{78.5 \text{ N}}$$